

Sensor couplings

Advantages at a glance

- Sensors provide best possible safety during the coupling process
- Increased safety even in poor visibility
- A remote display processes the signal and displays it in the driver's cab

Technical Features

- A sensor permanently monitors the connection status
- A second sensor controls the position of the king pin
- An additional third sensor monitors the contact locking position and displays it in the driver's cab.
- The sensors are located in protected zones on non-moving parts
- Electromagnetical compatibility according to highest standards
- Also suitable for use in the transport of dangerous goods (ADR)

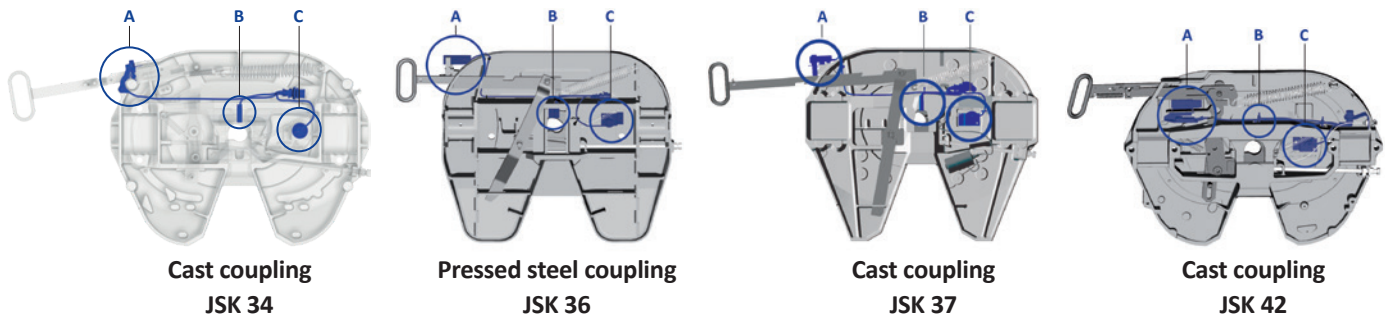

- A** = Sensor for connection status
- B** = Sensor for king pin
- C** = Sensor for coupling height



Selection table / Versions available

JSK 34

Order No.	H (mm)	S (mm)	X	Y	D value (kN)	Imposed load U (t)	Weight (kg)	Approval (ECE)	WA	Hole pattern design	ZL	Version
JSK 34 H0 20 CY AA	150	–	12°	12°	120	16	118	E1 55R-01 2482	LT5P ST	–	J	Standard
JSK 34 H0 38 C6 AA	185	–	15°	15°	120	16	120	E1 55R-01 2482	Z	–	J	Standard
JSK 34 H6 40 C6 AA	190	–	15°	15°	120	16	130	E1 55R-01 2482	Z	–	J	X ¹
JSK 34 H6 40 BC AA	190	–	15°	15°	120	16	126	E1 55R-01 2482	W+LT1P	–	J	X ¹
JSK 34 H6 40 CY AA	190	–	15°	15°	120	16	133	E1 55R-01 2482	LT5P ST	–	J	X ¹
JSK 34 H6 57 C6 AA	225	–	15°	15°	120	16	134	E1 55R-01 2482	Z	–	J	X ¹
JSK 34 H6 57 CY AA	225	–	15°	15°	120	16	136	E1 55R-01 2482	LT5P ST	–	J	X ¹
JSK 34 H8 21 P0 AI	160	362,5	12°	12°	120	16	135	E1 55R-01 2482	W+LT1P	G	K	Volvo/Renault
JSK 34 H8 21 O9 AI	160	337,5	12°	12°	120	16	135	E1 55R-01 2482	W+LT1P	H	K	Volvo/Renault
JSK 34 H8 44 P0 AI	200	362,5	17°	17°	120	16	139	E1 55R-01 2482	W+LT1P	G	K	Volvo/Renault
JSK 34 H8 44 O9 AI	200	337,5	17°	17°	120	16	139	E1 55R-01 2482	W+LT1P	H	K	Volvo/Renault
JSK 34 H0 20 AM CL	150	–	12°	12°	120	16	122	E1 55R-01 2482	LT5P	–	J	MAN
JSK 34 H0 38 AM CL	185	–	15°	15°	120	16	126	E1 55R-01 2482	LT5P	–	J	MAN

¹ Standard version without cable or display

Sensor couplings in the version ST (Standard) are complete sets, they are delivered incl. remote display (SKE501620200) and cable set (SKE002110300).

Technical Specification

Sensor coupling system in accordance with the ECE R55-01, TÜ.EGG.095-05, DIN 74081, ISO 3842, ECE R10 directives/standards. Suited for picking up 2" king pins (class G50) in accordance with ECE R55-01, DIN 74080, ISO 337 and steering wedges in accordance with ECE R55-01, DIN 74085.

Selection table / Versions available

JSK 36 – Plate coupling

Order No.	H (mm)	D value (kN)	Imposed load U (t)	Weight (kg)	Customer hole pattern	Approval (ECE)	ZL	WA	Version
JSK 36 DV 20 C6 AA	150	152	20	122	DIN	E1 55R-01 0301	J	M	Standard*
JSK 36 DV 31 C6 AA	172	152	20	122	DIN	E1 55R-01 0301	J	M	Standard*
JSK 36 DV 38 C6 AA	185	152	20	124	DIN	E1 55R-01 0301	J	M	Standard*
JSK 36 DV 47 C6 AA	205	152	20	128	DIN	E1 55R-01 0301	J	M	Standard*
JSK 36 DV 57 C6 AA	225	152	20	130	DIN	E1 55R-01 0301	J	M	Standard*



Selection table / Versions available

JSK 37 – Cast coupling

Order No.	H (mm)	D value (kN)	Imposed load U (t)	Weight (kg)	Customer hole pattern	Approval (ECE)	ZL	WA	Version
JSK 37 C0 20 C6 AA	150	152	20	146	DIN	E1 55R-01 0116	J	M	Standard*
JSK 37 C0 20 C7 AA	150	152	20	146	DIN	E1 55R-01 0116	J	W	Standard*
JSK 37 C0 20 DA AA	150	152	20	148	DIN	E1 55R-01 0116	J	LT5P	Standard*
JSK 37 C0 38 C6 AA	185	152	20	148	DIN	E1 55R-01 0116	J	M	Standard*
JSK 37 C0 38 C7 AA	185	152	20	148	DIN	E1 55R-01 0116	J	W	Standard*
JSK 37 C0 38 Z3 AA	185	152	20	148	DIN	E1 55R-01 0116	J	LT5P	Standard*
JSK 37 C0 20 AM CL	150	152	20	148	DIN	E1 55R-01 0116	J	LT5P	MAN
JSK 37 C0 38 AM CL	185	152	20	148	DIN	E1 55R-01 0116	J	LT5P	MAN
JSK 37 C0 20 M3 EX	150	152	20	146	DIN	E1 55R-01 0116	J	Z	Mercedes-Benz
JSK 37 C0 20 BE EE	150	152	20	148	DIN	E1 55R-01 0116	J	W+LT1P	Mercedes-Benz
JSK 37 C0 20 BF EE	150	152	20	148	DIN	E1 55R-01 0116	J	LT5P	Mercedes-Benz
JSK 37 C0 38 M3 EX	185	152	20	148	DIN	E1 55R-01 0116	J	Z	Mercedes-Benz
JSK 37 C0 38 BE EE	185	152	20	148	DIN	E1 55R-01 0116	J	W+LT1P	Mercedes-Benz
JSK 37 C0 38 BF EE	185	152	20	148	DIN	E1 55R-01 0116	J	LT5P	Mercedes-Benz
JSK 37 C0 20 P1 AI	150	152	20	146	DIN	E1 55R-01 0116	K	M	Volvo/Renault
JSK 37 C0 20 P4 AI	150	152	20	148	DIN	E1 55R-01 0116	K	W+LT1P	Volvo/Renault
JSK 37 C0 20 P2 AI	150	152	20	148	DIN	E1 55R-01 0116	K	LT5P	Volvo/Renault
JSK 37 C0 38 P1 AI	185	152	20	148	DIN	E1 55R-01 0116	K	M	Volvo/Renault
JSK 37 C0 38 P4 AI	185	152	20	148	DIN	E1 55R-01 0116	K	W+LT1P	Volvo/Renault
JSK 37 C0 38 P2 AI	185	152	20	148	DIN	E1 55R-01 0116	K	LT5P	Volvo/Renault

Sensor couplings

Spare parts JSK 34

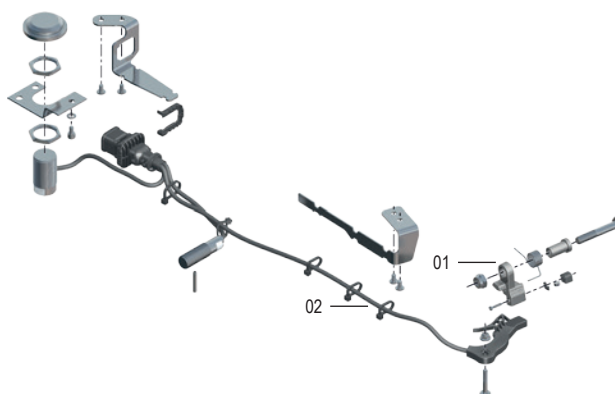

Item	Description	Remark	Order No.	
01	Latch with magnet		SKE001187307	1
02	3-sensor cable harness with mounted retaining plate - Standard		SKE001187311	1

Spare parts JSK 36 + 37

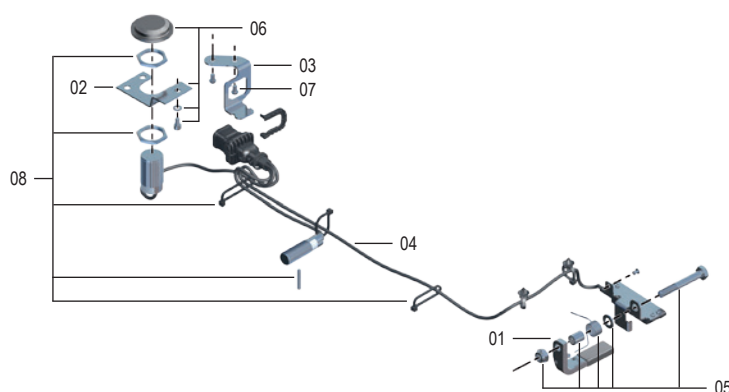

Item	Description	Remark	Order No.	per sensor coupling
01	Latch with locking magnet JSK 36	with 05	SKE100399300	1
01	Latch with locking magnet JSK 37	with 05	SKE002905104	1
04	3-sensor cable harness with retaining plate for locking sensor JSK 36 (pole round plug)	03, 04, 05, 06, 07, 08	SKE002040400	1
04	3-sensor cable harness with retaining plate for locking sensor JSK 36 (pole angular plug)	03, 04, 05, 06, 07, 08	SKE006140300	1
04	3-sensor cable harness with retaining plate for locking sensor JSK 37 – Standard/Mercedes-Benz	03, 04, 05, 06, 07, 08	SKE006140101	1
04	3-sensor cable harness with retaining plate for locking sensor JSK 37 – Volvo	03, 04, 05, 06, 07, 08	SKE006350110	1
09	Sensor display with 3 sensors – 24 V (European standard)		SKE501620200	1
09	Sensor display with 3 sensors – 12 V		SKE501620500	1
oZ	Connection cable, ADR quality (7-pole round plug)		SKE002110300	1
oZ	Adapter cable (pole round plug vs pole angular plug)		SKE011300000	1

Standard fifth wheel couplings can not be retrofitted with sensors.